

4

3

2

1

REVISIONS			
REV.	DESCRIPTION	DATE	APPROVED
A	INITIAL RELEASE	3/9/2022	BS

B

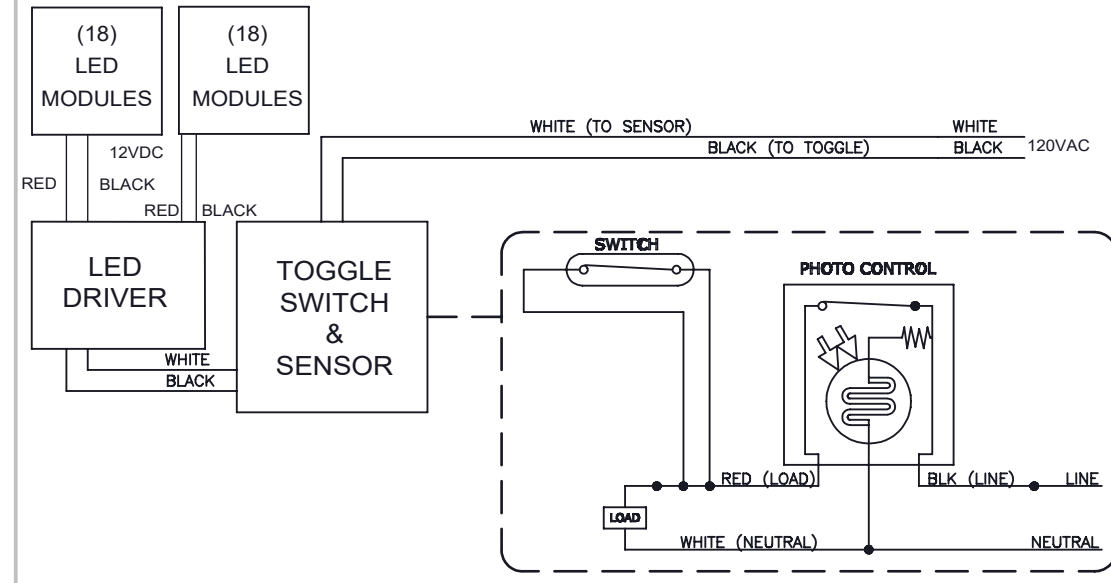

0.418A TYP (0.8A MAX) CURRENT DRAW 120VAC

STARBUCKS DRIVE-THRU ELECTRICAL COMPONENTS

ITEM NO.	PART NO.	DESCRIPTION	QTY
1	NA	STUB UP LOCATION IN STEEL MOUNT PLATE	1
2	218-012-0132	ROOF WIRING CONNECTOR PLATE	1
3	0081-0101	90 DEGREE 1/2" CONNECTOR 3422-8	3
4	218-000-0034	SLOAN LED DRIVER	1
5	218-002-0010S	POST PANEL COVER WIRED	1
6	228-000-0044	PHOTO SENSOR	1
7	0150-0004	TOGGLE SWITCH	1
8	0024-0050	SLOAN PRISM LED MODULES	36
9	0150-0010	RUBBER BOOT(FOR SWITCH)	1
10	228-000-0054	INDICATOR ON/OFF STICKER	1
11	0035-0014	LIGHT SHIELD	1
12	0018-0079	ANACONDA FLEX CONDUIT	3

E

- 4
- 6
- 7
- 3

SECTION A-A SCALE 1 : 28

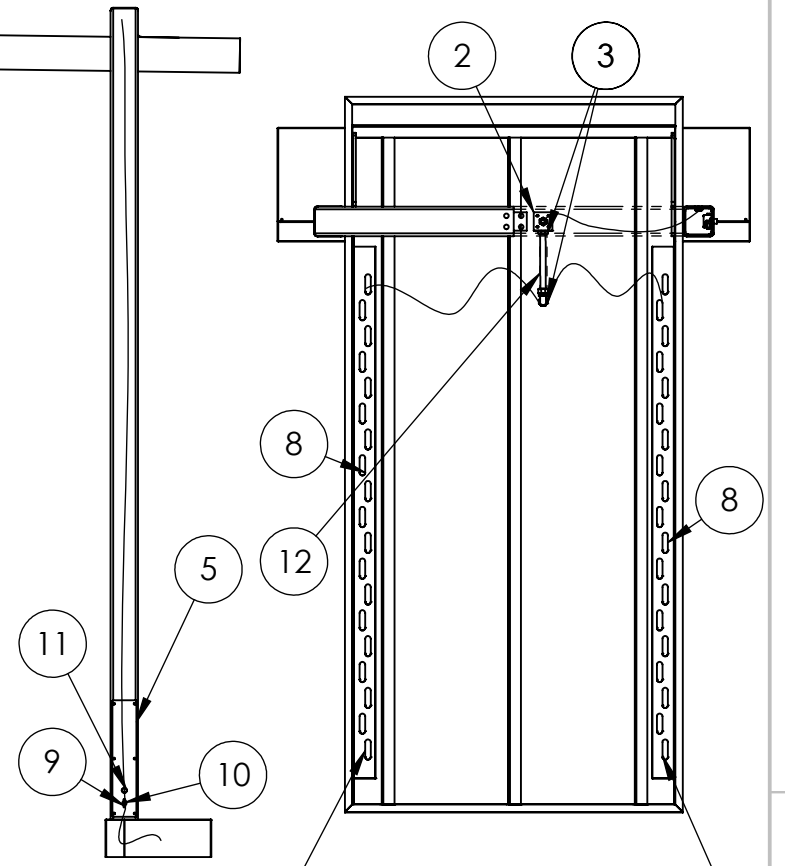
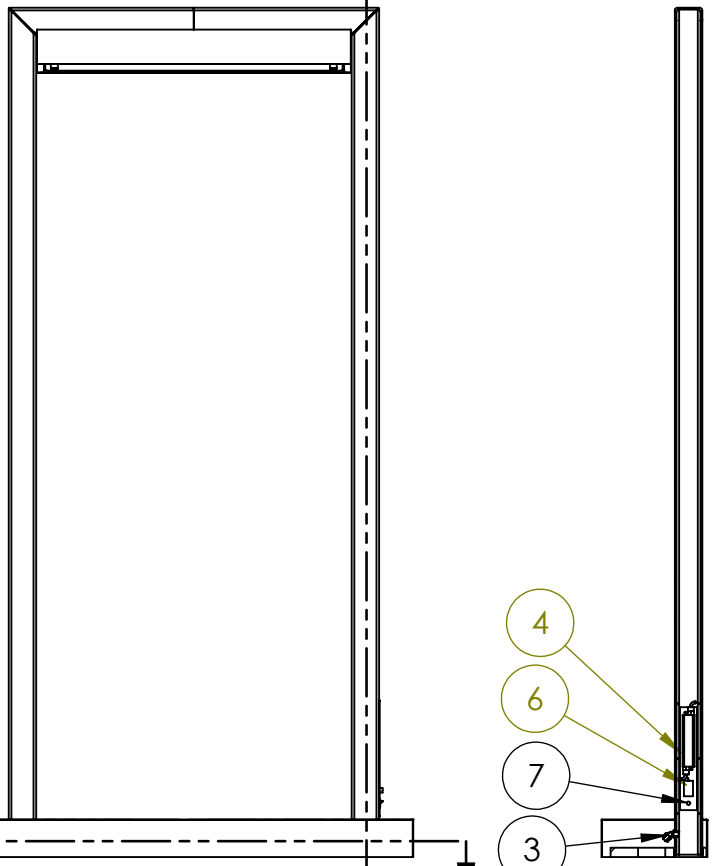

TOP VIEW

DECORATIVE LED LIGHTING

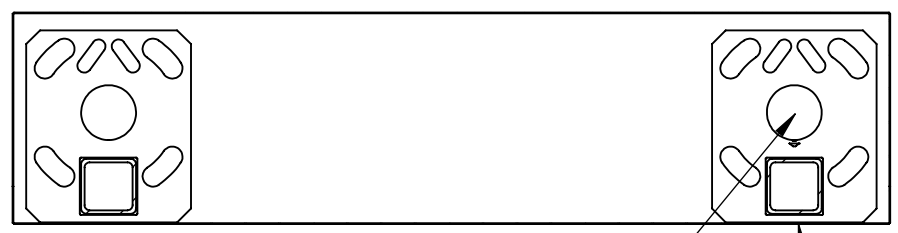

SECTION E-E SCALE 1 : 14

FRONT EDGE

STARBUCKS REVO OPC  
TITLE: ELECTRICAL

WEIGHT: 623.47	DRAWN BY:	NAME	DATE 5/5/21	DWG. NO.	REV
MATERIAL:	RAW PART #:			<b>SBROPCELECSBUX</b>	A
FINISH: PSB6865 BLACKBOARD DO NOT SCALE DRAWING	RAW QTY:			SCALE: 1:28 SHEET SIZE: <b>B</b>	SHEET 1 OF 1

4

3

22543

2

1

A

A